

**C95-15RS
 REMOTE PTT SWITCH
 P/N 40800G-01
 INSTALLATION SHEET**

The C95-15RS Remote PTT Cable (labeled as Item 3 in Fig. A) is available to the Captain and the Co-Captain if this feature is desired. This feature allows both the Captain and/or Co-Captain to transmit over the radio. The C95-15RS functionality is similar to the U9510BS except from a fixed location. A remote PTT switch can be mounted on the boat's throttle for easy access to the Captain or whoever is driving the boat, thus eliminating the need to have to reach down to the belt station to transmit. It is extremely important to remember that the corresponding belt station still has to have the RAD/IC switch switched to the RAD position before the user can transmit over the selected radio.

Tie-wrap the remote PTT switch end of the cable to its final destination (Captain or Co-Captain position) and route the cable to the Master Station. Always leave a 2 to 3 foot service loop at the Master Station end of the cable for cable prep at the Master Station. If both Captain and Co-Captain are to have the remote PTT function, then two C95-15RS Remote PTT Switches will be needed, one for each.

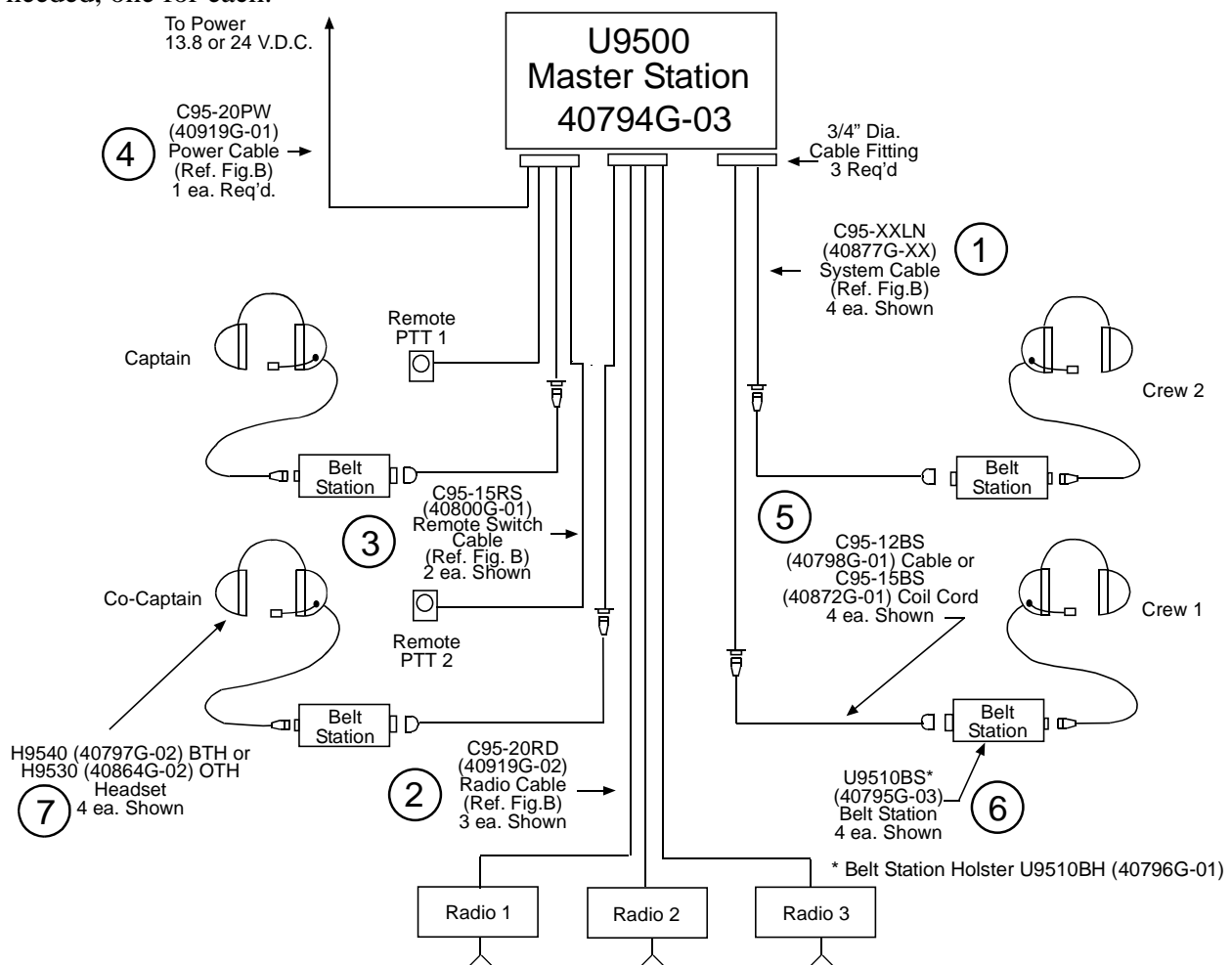
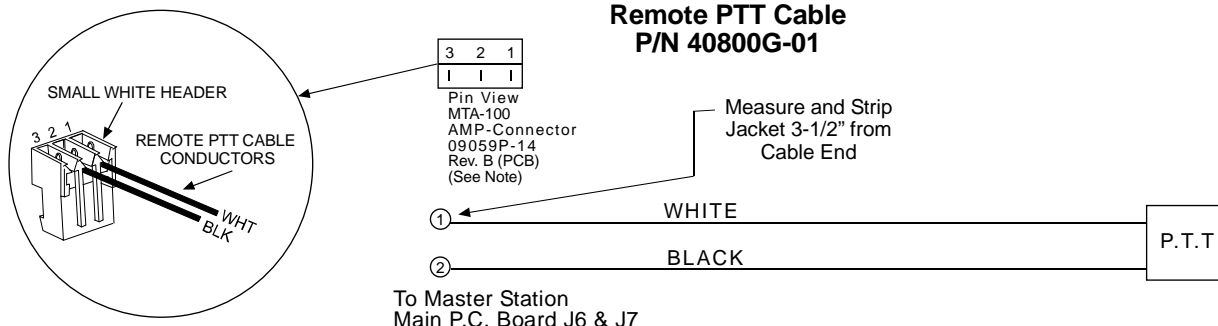
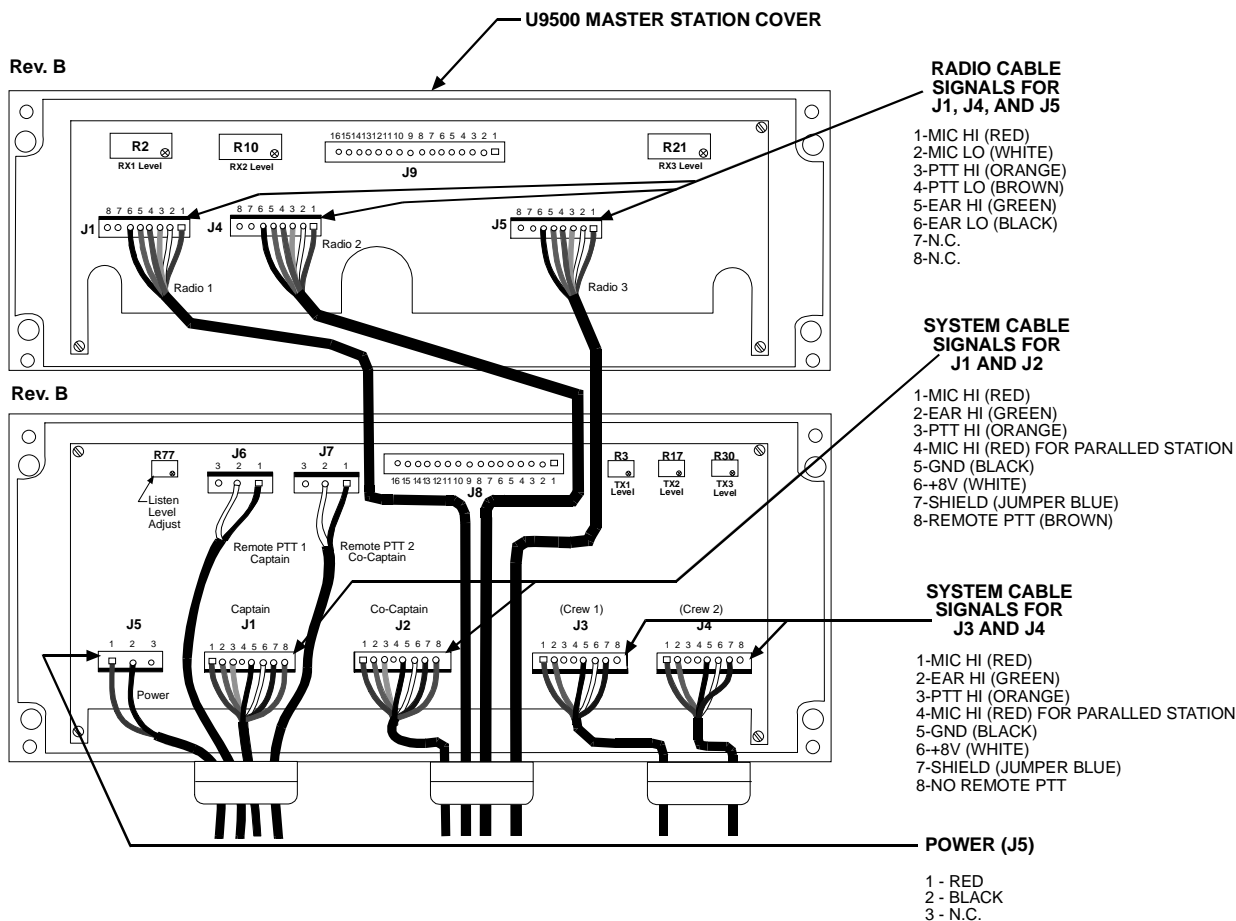

Fig. A Marine Intercom System Block Diagram

**C95-15RS
Remote PTT Cable
P/N 40800G-01**



Note: Use Amp tool 59803-1 to punch down wires



**Installation Wiring Configurations
Fig. B**